

ISATRONIC

Cal. 220B
(220/130)

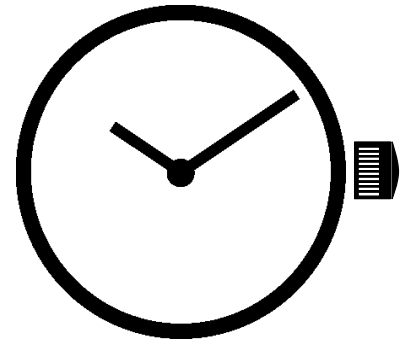

10 1/2 '''
23.30 mm
H. 1.60



SLIM
2 HANDS

ISASWISS
WATCH MECHANISMS

In conformity with RoHS standard

Caractéristiques :

Mouvement 2 aiguilles.
Mouvement électronique à quartz. Moteur rotatif pas à pas, 12 pas par minute.
Dispositif stop mécanique et électronique.
Tige 2 positions.
6 rubis.

Characteristics :

Movement with 2 hands.
Electronic quartz movement. Rotary stepping motor, 12 steps per minute.
Stop device and current breaker.
2 handsetting positions.
6 jewels.

Spezifikationen :

2-Zeiger Werk.
Elektronisches Quarzwerk. Schrittschaltmotor mit 12 Schritten pro Minute.
Möglichkeit mechanisch oder elektronisch zu stoppen
2 Stellwellenpositionen
6 Steine.

Critères Criteria Kriterium	Conditions Conditions Bedingungen	Min.	Typ.	Max.	Unités Units Einheit
Consommation - Current consumption Stromaufnahme	U=1.55V T=25°C		0.55		µA
Marche instantanée - Instantaneous rate Momentaner gang	U=1.55V T=25°C	-0.3 (-9)		+0.6 (+18)	s/jour s/day s/Tag ((s/mois s/month s/Monat)
Température de fonctionnement Operating temperature Betriebstemperatur		0		50	°C
Résistance aux champs magnétiques Resistance to magnetic fields Magnetfelddabschirmung			1500 (18.8)		A/m (Oe)

Qté Qty Menge	Désignation Designation Bezeichnung	Type Model Typ	Tension Voltage Spannung	Code Code Kode	Capacité Capacity Fähigkeiten	Autonomie théorique Theoretical Autonomy Theoretische Gangreserve
1	Pile Battery Batterie 7.90 x 1.65	SR 716 SW	1.55 V	315	21 mAh	52 mois months Monat

CAGE / FRAME

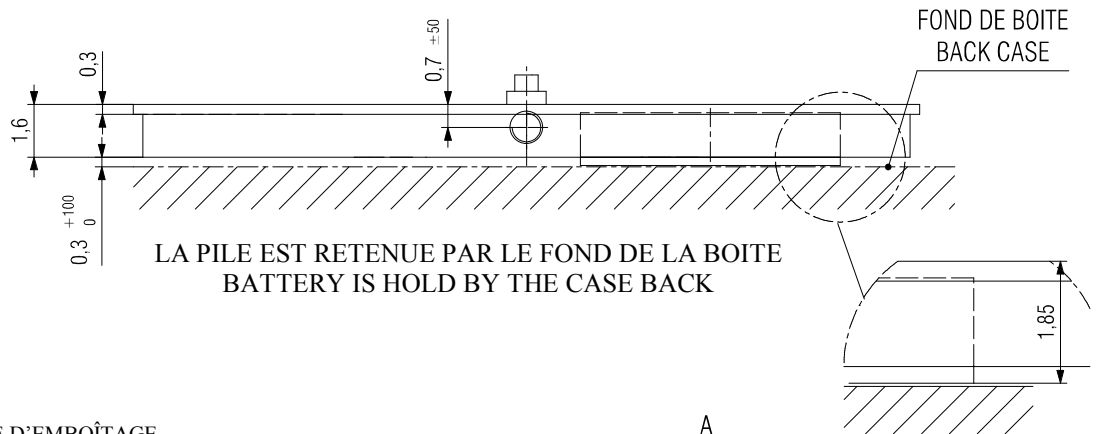

CLEFS DE FIXE OU CERCLE D'EMBOÏTAGE
CASE SCREWS OR CASING RING
AUTRES FIXATIONS POSSIBLES
OTHER FASTENINGS POSSIBLE

EMBOÏTAGE PAR LE VERRE / TOP CASING
Coupe / Cut A-A

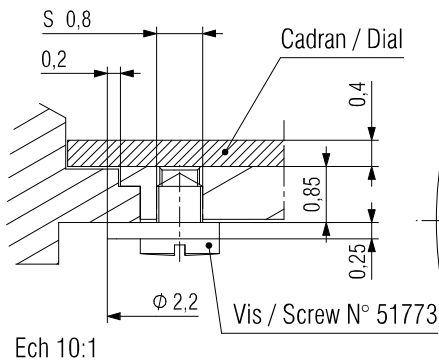

EMBOÏTAGE PAR LE FOND / BOTTOM CASING
Coupe / Cut A-A

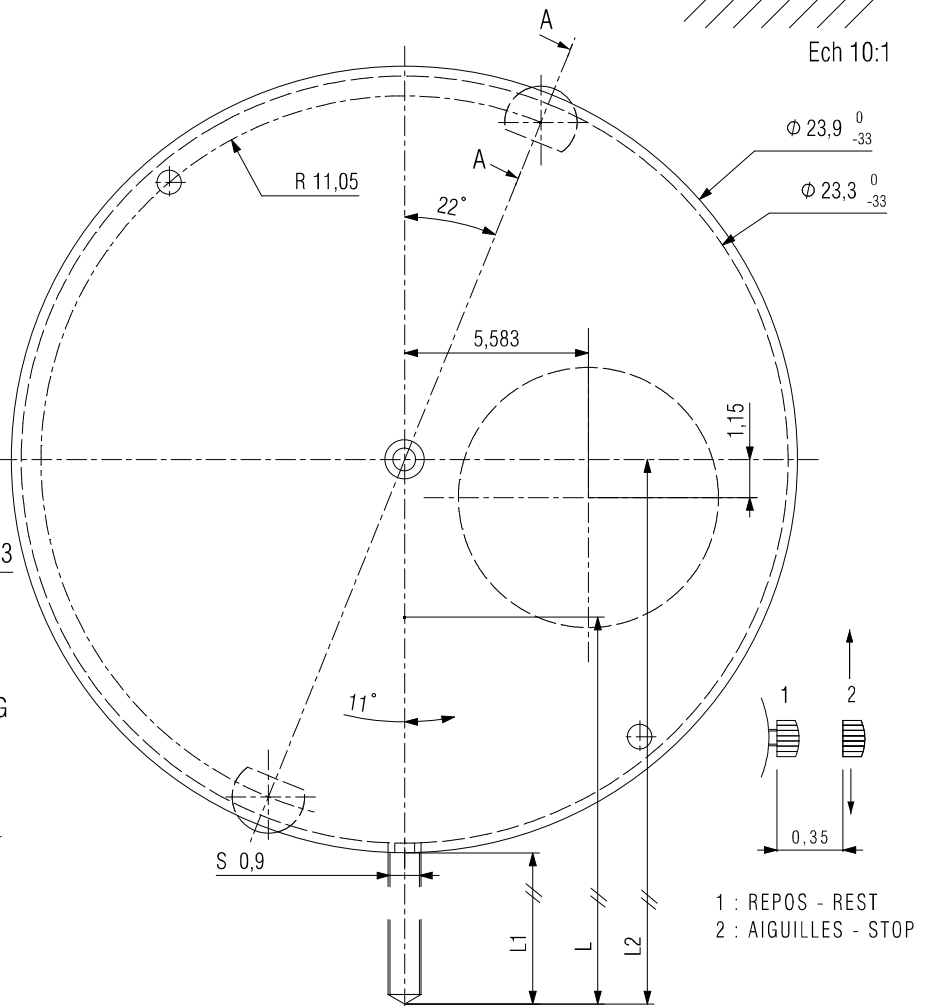
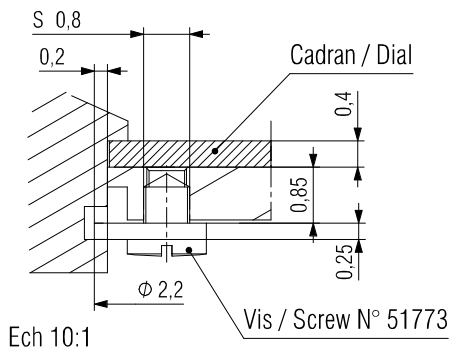

Tige en position repos / Stem in rest position	L	L1	L2
Standard / Standard	17.96 ±100	8.7	20.65
Longue / Long	25.00 ±100	15.7	27.65

DIMENSIONS IN mm. - TOLERANCES IN µm.

In conformity with RoHS standard

Doc. n° 0312174 - F - Up date : 11/03/2015 - Page 3

CADRAN / DIAL

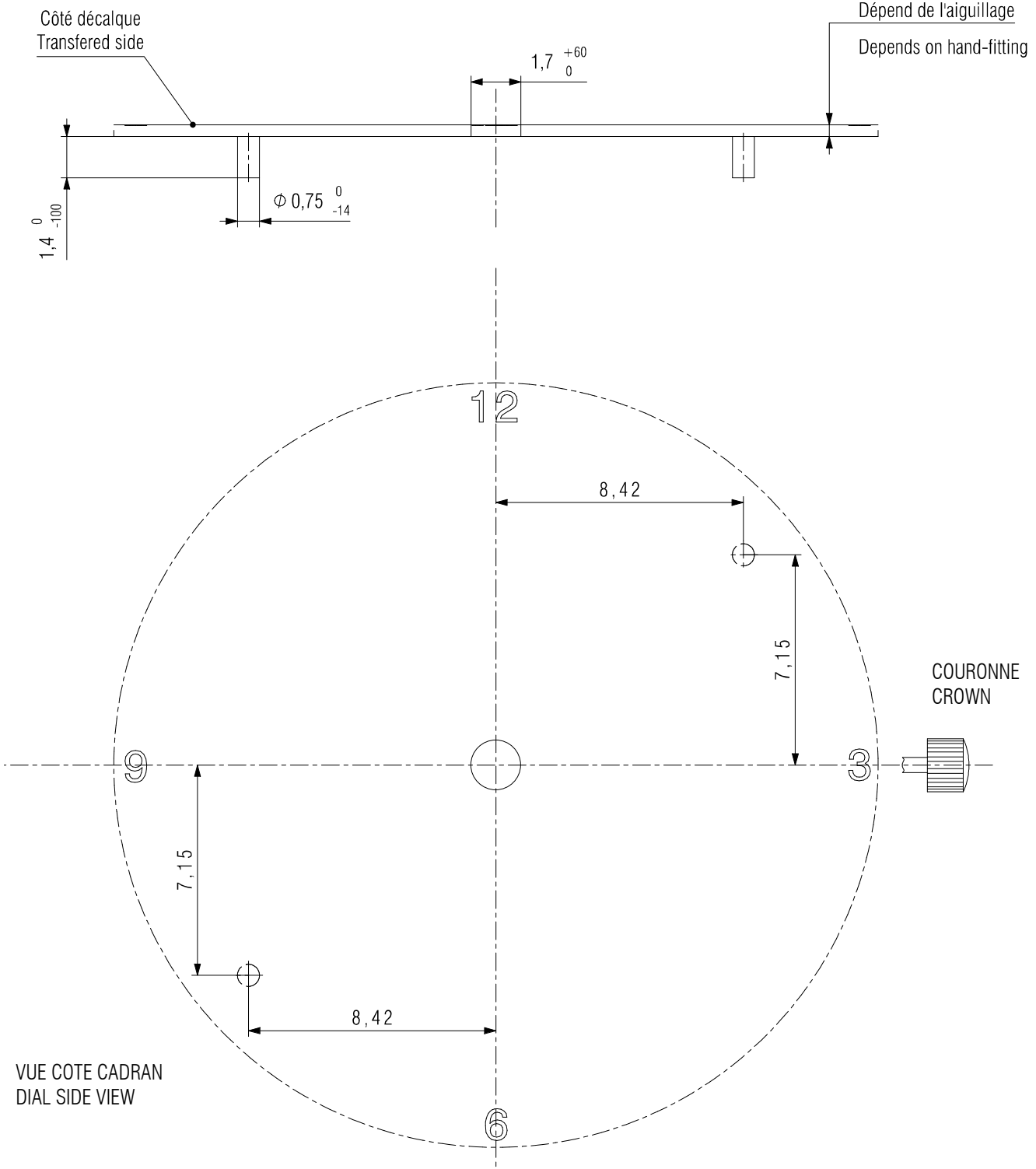

VUE COTE CADRAN
DIAL SIDE VIEW

DIMENSIONS IN mm. - TOLERANCES IN μm.

In conformity with RoHS standard

Doc. n° 0312174 - F - Up date : 11/03/2015 - Page 4

AIGUILLAGE / HAND-FITTING

AUTRES AIGUILLAGES SUR DEMANDE
OTHER HAND-FITTING ON REQUEST

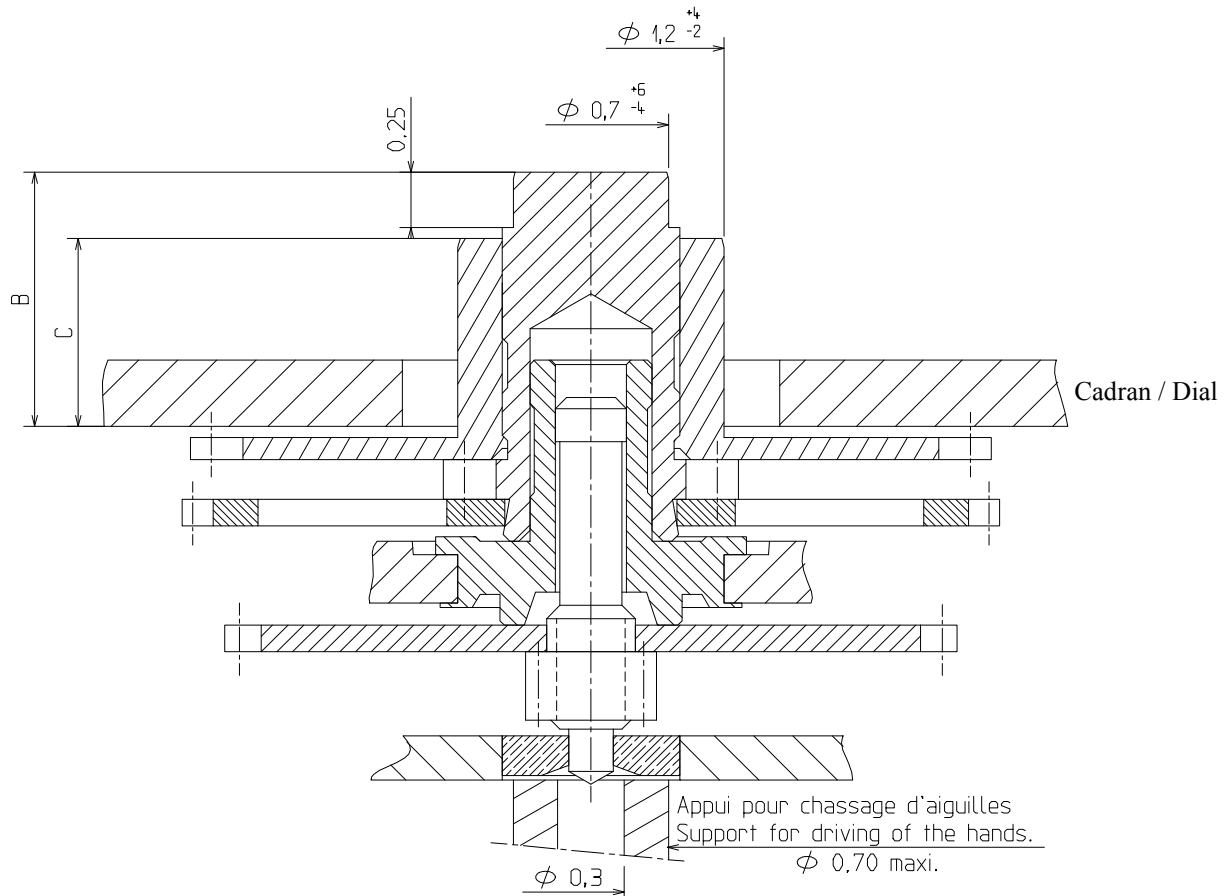

AIGUILLAGE / HAND-FITTING	Dépassement / Height over dial seat		Epaisseur cadran / Dial Thickness
	B	C	
	Chaussée / Cannon pinion	Roue des heures / Hour wheel	
N°1 Réduit / Reduced	0.90	0.60	0.30 maxi
N°2	1.15	0.85	0.40 maxi
N°3	1.40	1.10	0.65 maxi
Hauteur tube / Pipe height	0.25	0.50	-
CHOCs 450 g / 450 g SHOCKS	Balourd / Unbalance		FORCE DE CHASSAGE / PRESS-IN-FORCE
Aiguille des minutes - Minute Hand	≤ 1.1 µNm		≤ 25 N

DIMENSIONS IN mm. - TOLERANCES IN µm.

In conformity with RoHS standard

Doc. n° 0312174 - F - Up date : 11/03/2015 - Page 5